



KONE

PRECISE, SOLID, FAST AND QUIET EVERY TIME.

KONE High-Performance Door Systems

People judge the performance of an elevator by how well its doors work.

Doors that function improperly can create a negative impression among visitors. Constant shutdowns hurt the efficient operation of a building, reflect poorly on its management and increase downtime and expense. What is the condition of your elevator doors? Ask yourself:

- Are the doors noisy or erratic in operation?
- Do they open or close too slowly or too quickly?
- Do they sometimes fail to open or close at all?
- Do they occasionally strike passengers who are entering or exiting the elevator?
- Do constant shutdowns and malfunctions disrupt building operations?

If you answered “yes” to these questions, you need a KONE elevator door operation upgrade.

KONE Spares offers a variety of door operator solutions including: MAC, G2M and AMD. Your operator can be shipped, most cases, the same day an order is received. Plus, we can schedule installation to coincide with its arrival.

The components of the MAC, G2M and AMD door operators are outlined on the following pages. Every component is designed and engineered to stringent KONE standards. Each one is manufactured from the finest materials, which use the latest technology. You get the best – without compromise. That’s our commitment to you.



The average elevator door opens and closes more than 200,000 times a year. No wonder over 70% of all elevator trouble calls are related to the door operation.

G2M Door Operator Upgrades

The G2M Door Operator upgrade easily adapts to existing GAL door operator systems. The G2M Door Operator was designed to eliminate the problems of outdated GAL door systems, reduce maintenance/operating costs and provide superior door operation without complete replacement. KONE's G2M Door Operator upgrade features exceptionally smooth acceleration/deceleration "soft-start" circuitry. This solid-state control provides uniform door speed transitions.

The speed-regulation feature can be adjusted to compensate for differences in door weights, producing consistent operation from floor to floor.

Maintenance time is minimized as speed adjustments are quick and easy from the car top through the use of LED indicators.

Sealed bearings and a cool operating DC permanent-magnet motor extend the life of your door operator and reduce maintenance time.

All speed adjustments are performed quickly on the car top, with the guidance of LED indicators

An internal solid-state timer will remove power to protect the motor from overheating, if the doors don't fully open or close within a preset time

DC permanent-magnet motor – quiet, efficient and durable

Quiet belt-driven system

Drive linkage is reused, saving installation time and money

Sealed pillow blocks require no maintenance

Our flush-mounted infrared electronic sensing device reopens doors when people or objects disrupt the infrared plane

G2M Door Operator System

- May be applied to relay or microprocessor logic control systems.
- Will offer significant savings over complete door system replacement.
- Offers modular upgrades allowing replacement of hangers, tracks, pickup assemblies, etc., at a later time.

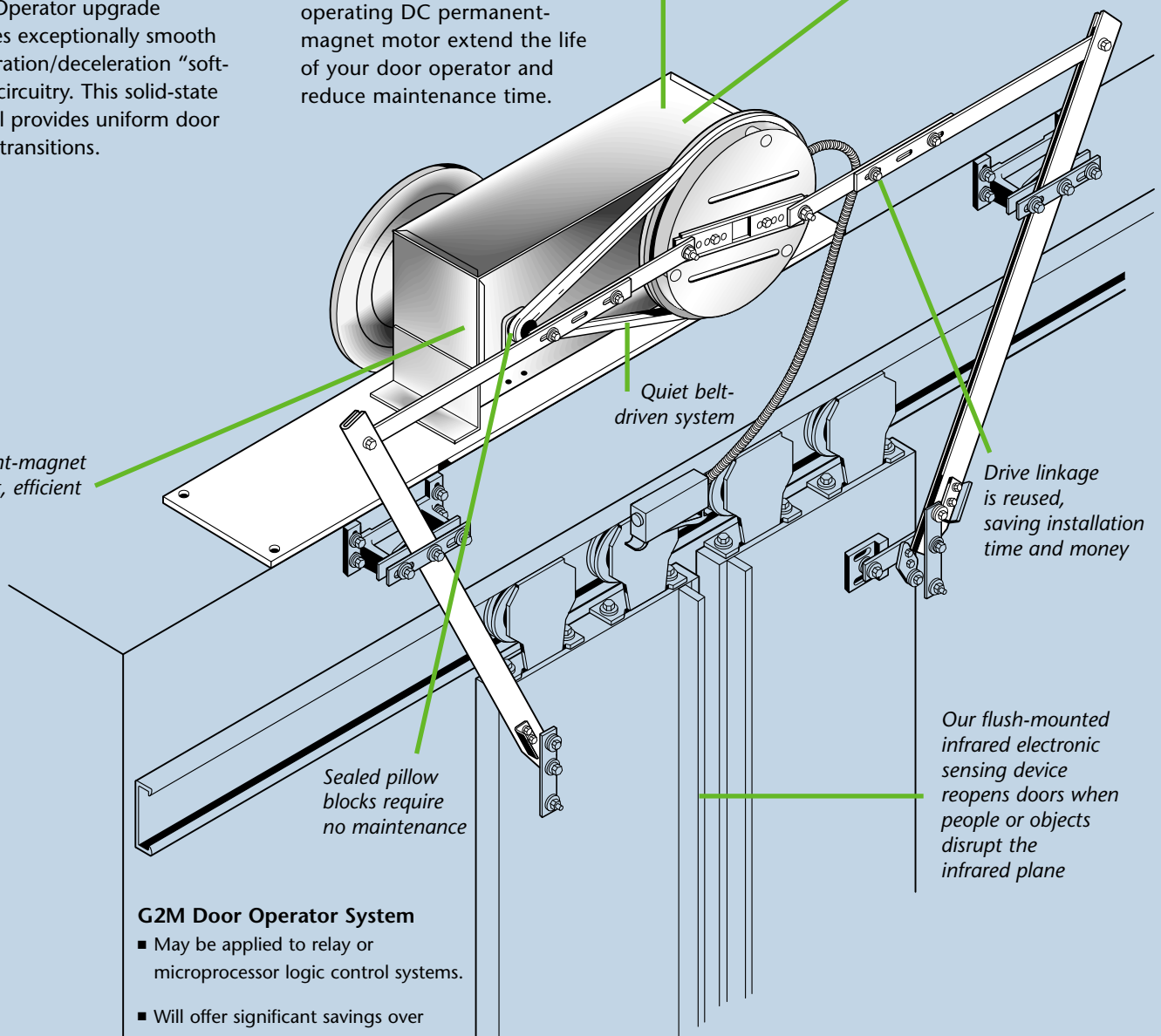

KONE AMD™ High-Performance Door Systems



KONE AMD High-performance Door Systems deliver precision you can feel. The mechanical coupling is sure and solid, allowing smooth linear action of the car doors and quiet operation. The action is swift and silent, consistent at each stop regardless of differing door weights and air pressure. Break the curtain of light and the doors retract positively, with amazing speed.

KONE AMD Door Systems handle every situation without skipping a beat. It's a function of KONE closed-loop control. The performance profile is set according to your specific needs. Then, operating conditions are monitored and digitally encoded feedback allows the system to learn about your building. A Permanent-Magnet Synchronous Motor (PMSM) and ingenious Variable Voltage Variable Frequency (V3F) drive use this information to ensure precise performance every time.

When demands change, KONE AMD changes easily to meet your needs. It's a simple matter of adjusting the performance profile to accommodate a change in your building or new passenger requirements. KONE AMD takes it from there, applying what it learns to maintain the new performance parameters. That means that once your elevator's performance profile is set, you can count on reliable, consistent door operation, regardless of variations in your building's environment.

Precise, solid, fast and quiet.



- 1 Elevator doors retract the instant the infrared beam light curtain is broken, virtually eliminating the chance of door contact with passengers.
- 2 KONE AMD Door Systems reduce operating noise by 50% compared to conventional operators.
- 3 KONE AMD Door Systems are designed and tested reliable for 800,000 elevator starts a year. That's almost four times the typical elevator demand.
- 4 V3F inverter drive integrated with door control electronics.
- 5 KONE AMD offers perhaps the fastest door-open times in the industry.
- 6 Synchronous PMSM motor, excitation by permanent magnets (no brushes).
- 7 KONE AMD features patented KONE technology.
- 8 Door coupling design, drive system and track allow for true "linear" motion.

MAC Door Operator

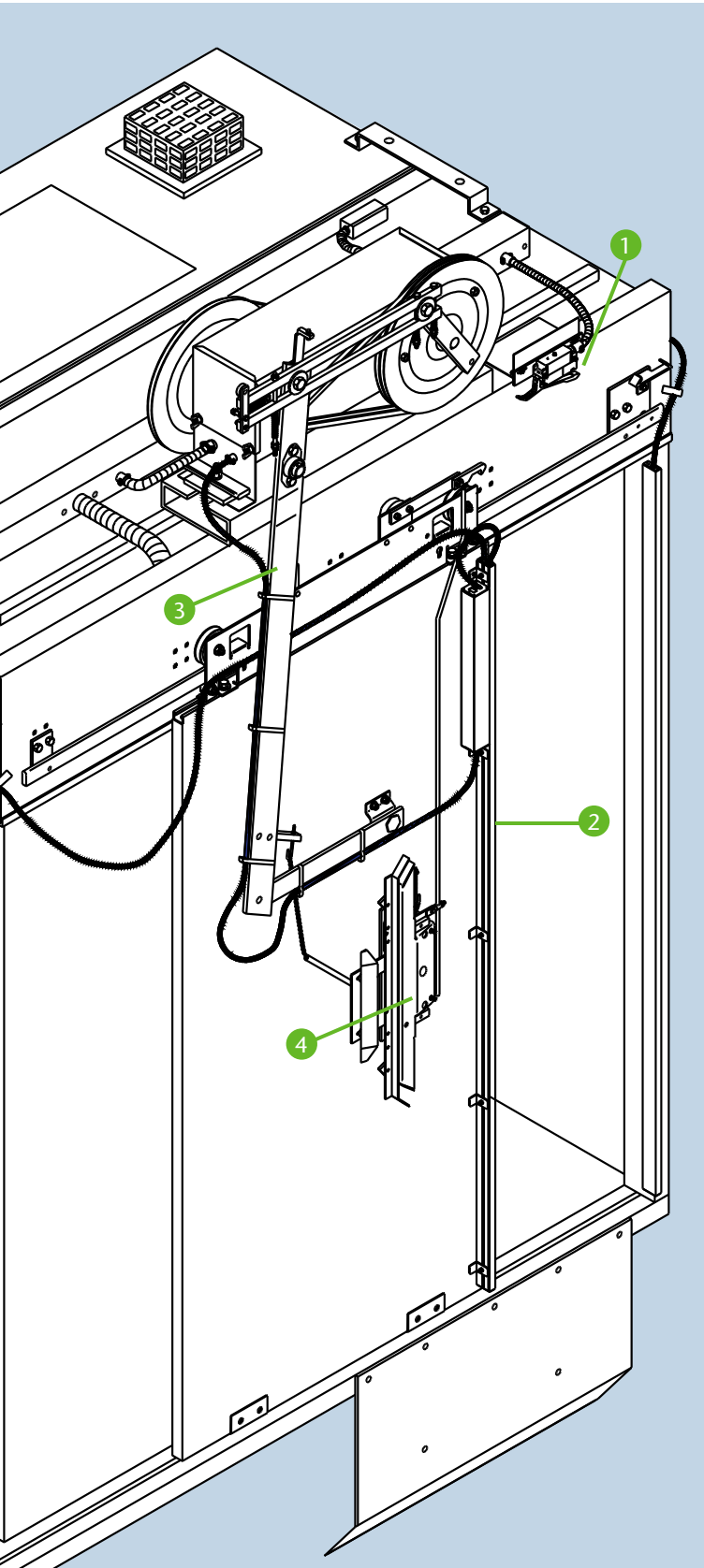

The MAC Closed-Loop Door Operator is a permanent-magnet solid-state and closed-loop operator which provides consistent high-performance door operation for all types of applications.

- Measures velocity feedback of the motor
- Measures position feedback of the doors
- Microprocessor control system
- Adjusts to various conditions, including door weights and wind resistance
- Meets consultant closed-loop specifications

1 Gate Switch

The purpose of the gate switch is to electronically lock the car doors. The elevator will not move until this switch is closed.

2 Door Sensing Device – Infrared Light Curtain

Upgrading to the Formula Systems FCU⁴⁷ Infrared Light Curtain increases passenger satisfaction and comfort while decreasing door-related callbacks and downtime. Forty-seven invisible infrared beams detect virtually any obstruction before the doors touch passengers or their property. Because it is mounted flush, it is protected from objects moving on or off the elevator.

The FCU⁴⁷ infrared electronic sensing device is very affordable and can be easily installed in any door operation system. The unit also includes buzzer/nudging interface as a standard feature. This self-contained diagnostic system simplifies maintenance.

3 Door Linkage

Precise control over door movement requires that the linkage between the doors and the door operator transmit movement to the doors efficiently, quietly and reliably. MAC door linkages are designed for heavy-duty use with maintenance-free sealed bearings.

4 Door Clutch

The MAC door clutches are designed to provide positive, quiet engagement with the hoistway doors while maintaining close tolerance clearances while the car is in motion.

MAC Door Operator

- 1 Hoistway Door Reel Closure**
The reel closure ensures that the hoistway doors close tightly. It must have adequate spring tension to pull the hoistway door shut and actuate the door interlock mechanism.
- 2 Hoistway Door Drive**
The hoistway door drive works together with the car door clutch to transmit the motion of the car doors to the hoistway doors. The MAC door drive system provides precise door control and quiet operation, while maintaining close tolerances with the moving car.
- 3 Hoistway Door Gibs**
Both the car and hoistway doors are guided at the sill with a device designed to allow freedom of door movement while providing secure positioning.
- 4 Hoistway Door Interlock**
The hoistway door interlock mechanically locks the door to prevent it from being opened unless the car is present and completes an electrical circuit to allow the elevator to move.
- 5 Facia**
The flat reinforced steel plate that is installed vertically inside the hoistway above the hoistway door hanger header to the sill of the landing above, prevent pinch points and ledges.
- 6 UL Fire-Rated Door Panels**
The fire-rated door panels are designed to resist standard fire tests and are labeled for identification.
- 7 Door Sill**
The hoistway sill is the bottom horizontal plate of the landing entrance which provides foundation and footing for the elevator entrance frame.

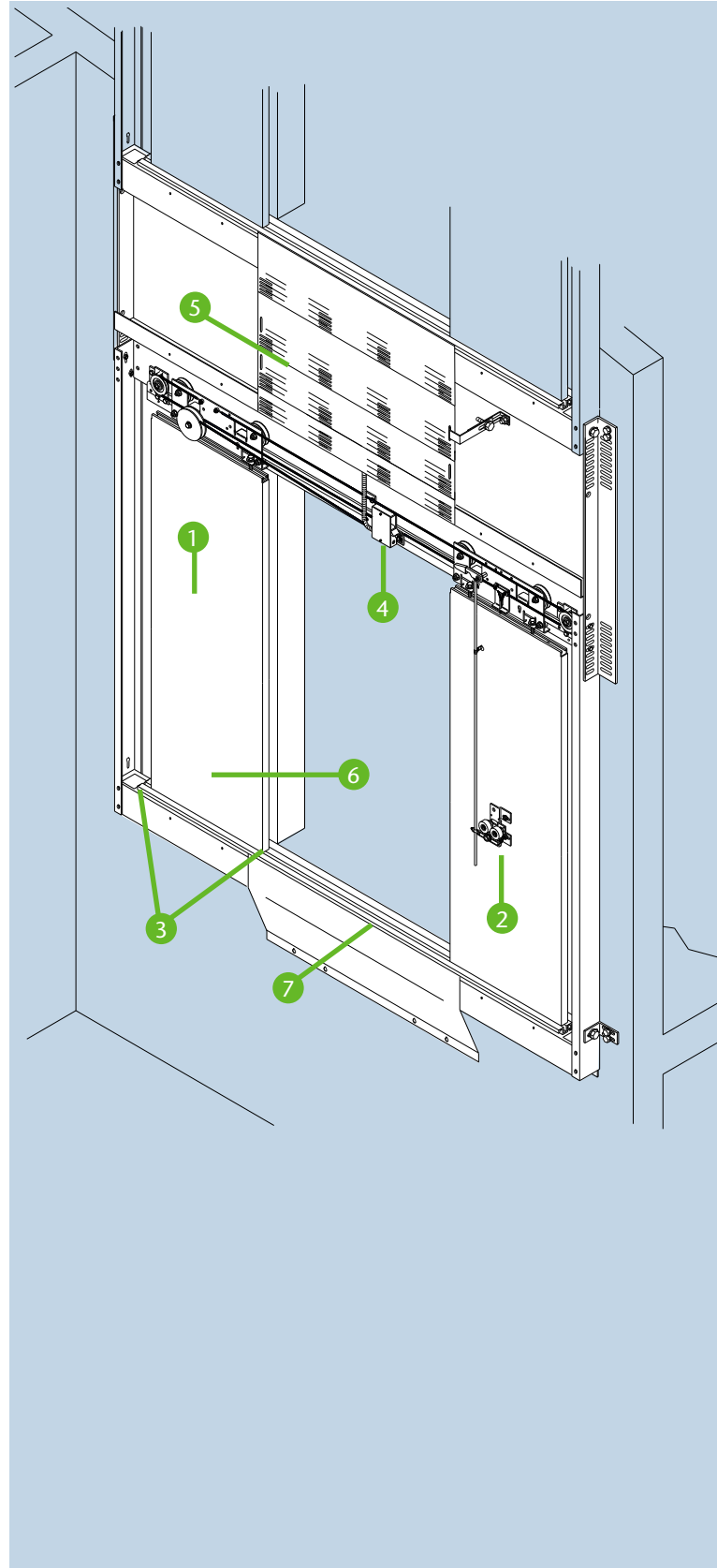



KONE Spares
325 19th Street
Moline, IL 61265
Tel: (800) 343-3344
Fax: (309) 743-5541
www.konespares.com

KONE Inc. reserves the right to alter design and specifications without prior notice.

KONE is a registered trademark of KONE Inc. AMD is a trademark of KONE Inc.

"USGBC" and related logo is a trademark owned by the U.S. Green Building Council and is used by permission.

