



SPARES CENTER

**Door Operator Conversion Package:
Type M to PM/SSC or HPM/SSC
with Board 1Ø4[®]**

Purpose

This product instruction provides a brief description of the features and components of the Type M (non-solid state) to PM/SSC or HPM/SSC (high performance) with Board 1Ø4® (solid state) Door Operator conversion package. This product instruction also provides Field Personnel with information on conversion procedures, operational checks and adjustments, and diagnostic procedures.

A606-001 (7/97)

© 1998 **MOLINE ACCESSORIES COMPANY**

This volume is not intended for distribution, and not approved for use as a source of information for any purpose or procedure. All rights reserved. No portion of this volume may be reproduced or used in any manner without written permission from Moline Accessories Company -- 107 18th Street; Moline, IL 61265

TABLE OF CONTENTS

Purpose	2
Safety	4
Description of PM/SSC door operator with Board 1Ø4®	5
Converting door operator components	6
Remove Type M components	6
Install Board 1Ø4® components	7
Wire Board 1Ø4® components	8
Install new cover	10
Adjusting door operator control Board 1Ø4®	11
Measure current (optional)	13
Set potentiometers	13
Adjust door speeds	14
Adjust door closing force	16
Adjust nudge speed	16
Set microswitch cams	17
Replacement Parts	18



Safety

Participate in the successful conversion procedures of MAC® Car Door equipment— know the safety hazards related to any procedure, know what equipment is required, and know what tools and materials you should plan to have available beforehand.

- Always consider safety first.
- Use a circuit tester on circuits prior to working on them.
- Avoid pinch points when handling materials.
- Make sure there is adequate lighting in the work space.
- Be aware of all tripping hazards.
- Make certain electrical outlets are protected with a ground fault circuit interrupter (GFCI).
- When working on the car top, always be aware of where you are in relationship to edge of car top.

A606-002 (7/97)



024 (3/97)



066 (2/97)

Description of PM/SSC door operator with Board 1Ø4®

The PM/SSC is a standard performance door operator, most commonly used, with a speed of 1FPS to 2 FPS (average 1.5 FPS, peak 2.5 FPS). The PM/SSC door operator with Board 1Ø4r has the following operations and features:

- ❑ Door control power
- ❑ Current control
- ❑ Speed & travel limits
- ❑ Acceleration & deceleration
- ❑ Diagnostics & switch adjusting
- ❑ Auxiliary piloting

Door control power. PM/SSC door operator control uses a low voltage permanent magnet DC motor. The DC motor is powered by pulse width modulated power (high speed switching - 20,000 hz). The motor responds to average voltage of high frequency pulses, and not individual pulses.

Current control. PM/SSC door operator control has a current sensing circuit in both open and closed directions to supply feedback to the speed control circuit. This current sensing circuit regulates closing door force, and open/stall current caused by a hooked interlock. The current sensing circuit also guarantees that PM/SSC door operator control relay contacts do not break or make when motor armature current is present—helping to prevent damage to relay contacts. Motor direction is controlled by reversing the armature connection using a conventional relay system.

Speed & travel limits. PM/SSC door operator control selects speed and travel limits with cam operated microswitches. These microswitches operate relays tied into the speed direction circuits.

Acceleration & deceleration. PM/SSC door operator control has an internal soft-start circuit which regulates smooth acceleration and deceleration. Soft-start circuit allows average motor voltage to change gradually when speeds change.

Diagnostics & adjusting switches. PM/SSC door operator control has two small toggle switches mounted on the common circuitboard. The TEST/RUN switch and O-OFF-C switch are used to:

- Signal door opening or closing from the car top during diagnostics and adjusting
- Disconnect the door open and close signals
- De-activate the internal shutdown timer

Auxiliary piloting. The PM/SSC door operator control also has a Form “C” Open and a Form “C” Closed relay contact for auxiliary piloting.

The Type M to PM/SSC door operator conversion kit contains the following.

- Door control with Board 1Ø4®/motor assembly
- PM/SSC bottom cover
- Cover (top)
- 13 connector cable for wiring microswitches
- Mounting hardware

A606-003 (7/97)

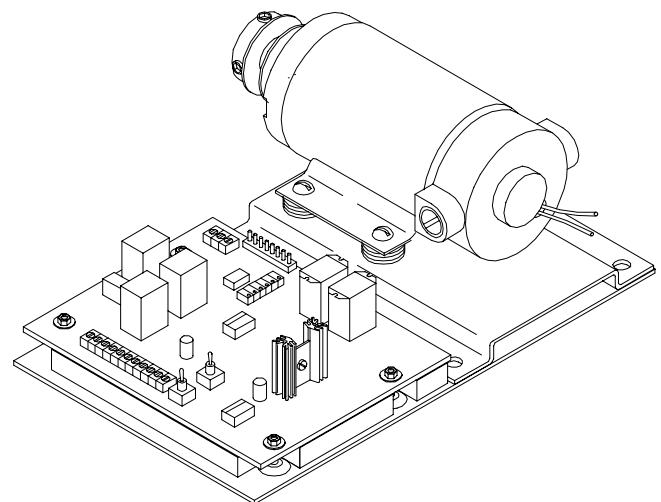

A606-011(7/97)

Door control with Board 1Ø4®/motor assembly

Converting door operator components

Complete the following to convert Type M door operator components to PM/SSC Board 1Ø4® door operator components.

- Removing Type M components
- Installing Board 1Ø4® components
- Wiring Board 1Ø4® components
- Installing new cover

REMOVE TYPE M COMPONENTS

1. Turn OFF electrical power to the door operator.
2. Remove existing microswitch cover.
3. Remove belt (1) from motor sheave (2) and door operator sheave (3).
 - ▶ Save belt for use with conversion kit.
4. Remove motor mounting hardware and remove old motor (4) and mounting plate.
5. Disconnect controller wires at door operator, and tag the wires for identification. Remove terminal board.
6. Remove all wiring to the microswitches - including jumpers.
7. Disconnect wires at controller, and tag the wires for identification.

Make sure the identification tags at the door operator and controller match.

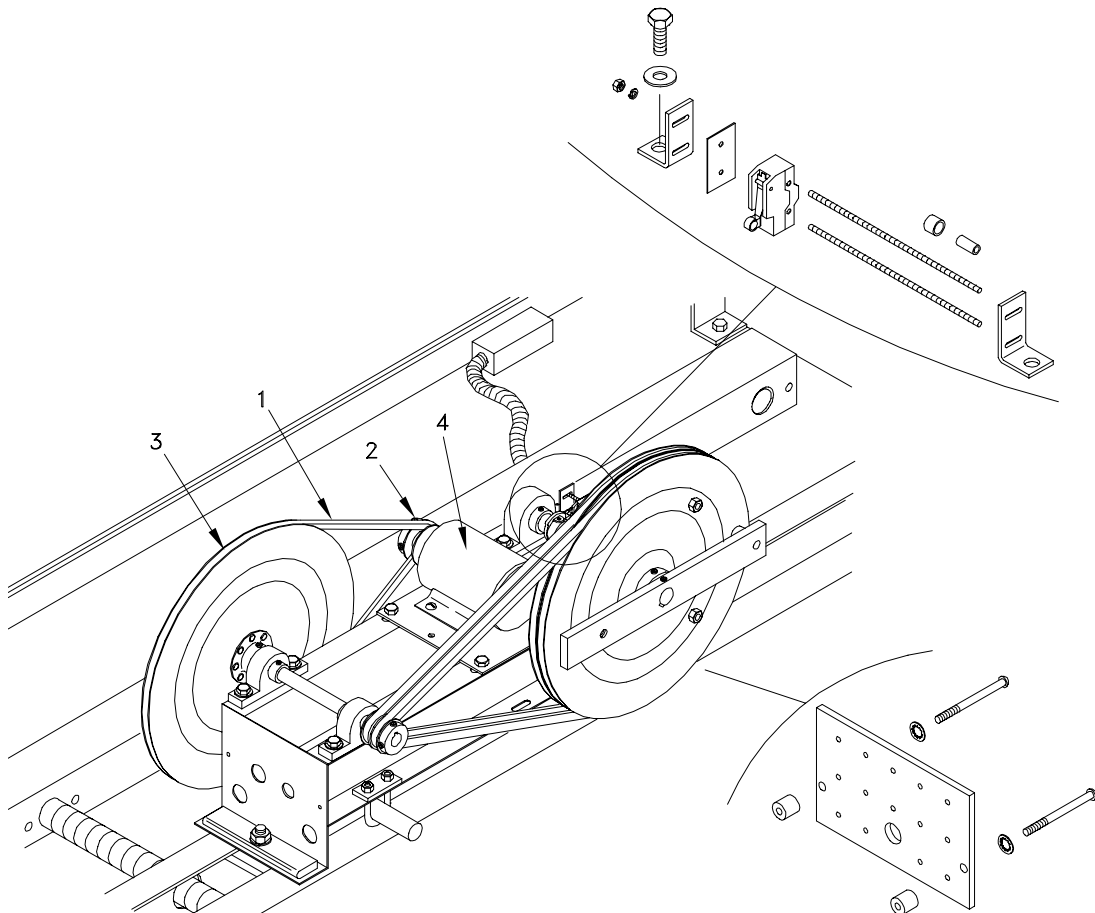

A606-008(4/98)

Older door operators could have cast spoke sheaves.

INSTALL BOARD 1Ø4® COMPONENTS

1. Install bottom cover (5).
2. Install Board 1Ø4® conversion kit assembly (6) with mounting hardware provided.
3. Install belt (1) on motor sheave (7) and door operator sheave (3).

Make sure motor sheave and door operator sheave are aligned when installing belt.

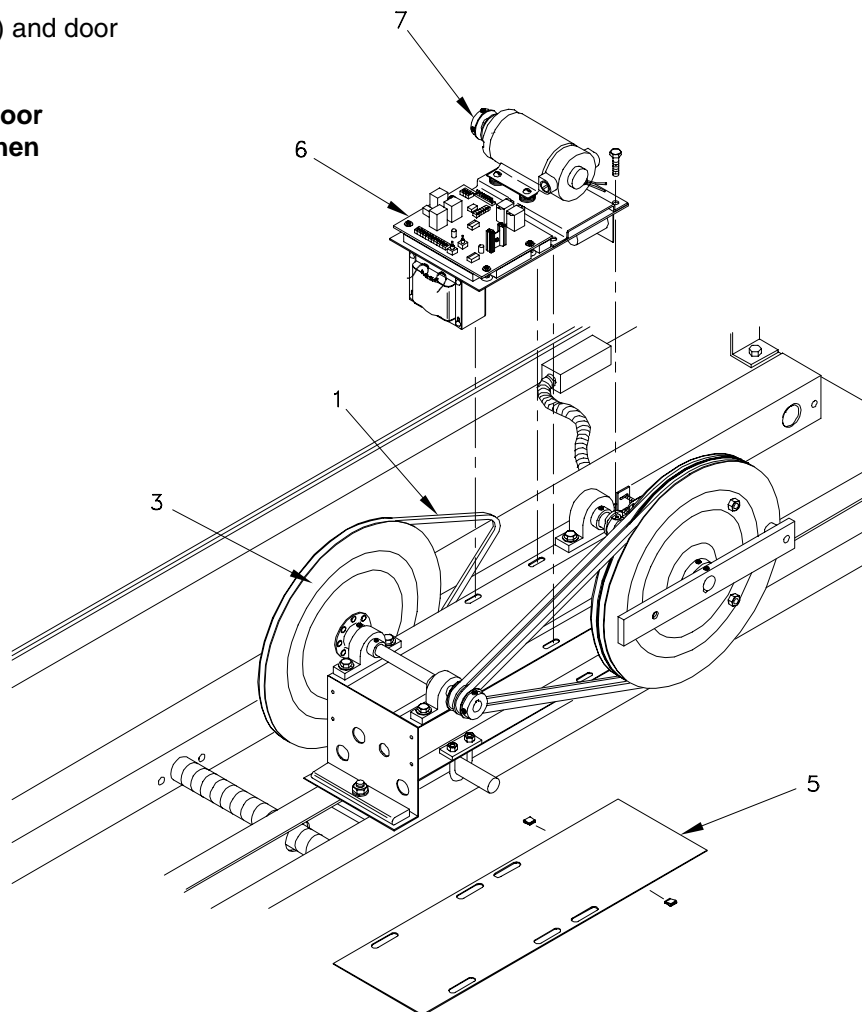

A606-007(3/98)

WIRE BOARD 1Ø4® COMPONENTS

1. Plug molex end of new 13 connector cable into CN1 on Board 1Ø4®.
2. Route cable under cams and wire into microswitch terminals.
 - If DSD is required, add DSD switch connections.
 - If DSD is not required, tape off connectors 12 and 13.

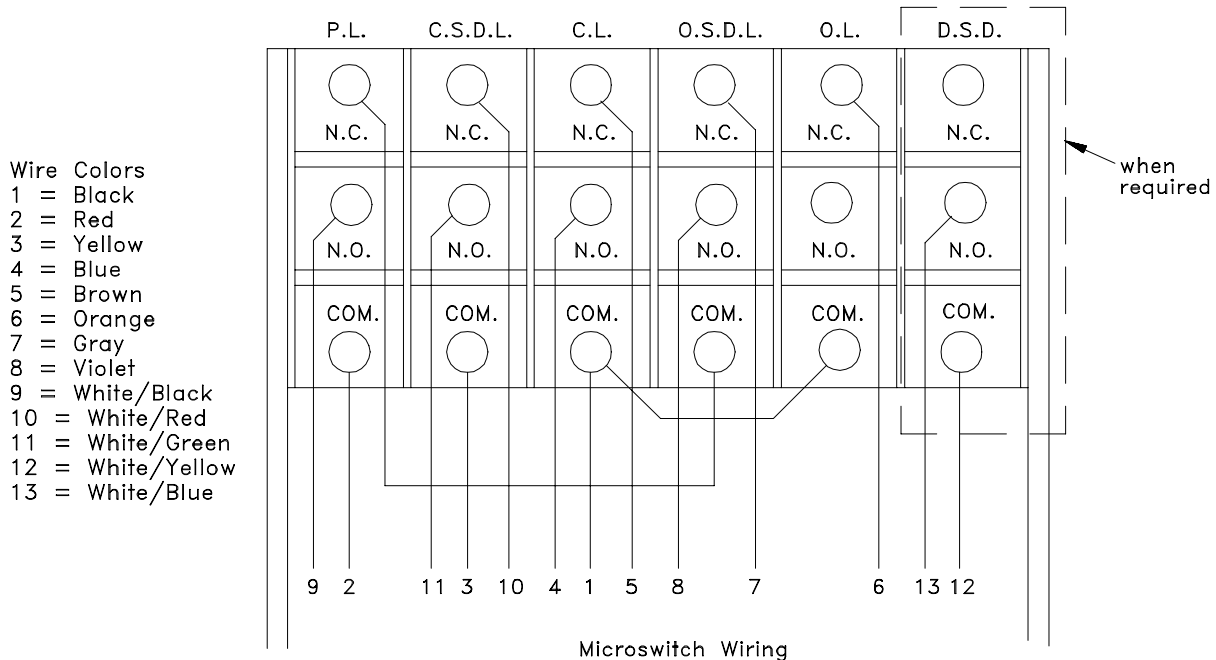

A603-124(4/93)

Input & Output Terminals

Required for door to operate

L1A to L2A 120VAC @ 500VA input. If one of input lines is grounded, it should be connected to L1A.

DO3 to L1A Open limit signal. A relay across these terminals de-energizes when open limit microswitch is actuated. Relay is energized at all other times.

DO7 to L1A Signal to close. When a relay contact across these terminals makes up, doors should close.

DO10 to L1A Signal to open. When a relay contact across these terminals makes up, the doors should open.

DO17 to L1A Close limit signal. A relay across these terminals de-energizes when close limit microswitch is actuated. Relay is energized at all other times.

Optional

DO4 to DO7 Reduced speed closing signal. When doors have a signal to close, and a relay contact across these terminals makes up, door speed is controlled by "N" potentiometer.

F NC NO Auxiliary C relay switching contact. C
Designates a Form "C" contact on a 1-C relay.

F NC NO Auxiliary O relay switching contact. O
Designates a Form "C" contact on 1-O relay.

DSD to SS Optional - Used on some projects for load balancing or other customer requirement.

A606-005 (3/98)

Door Operator Conversion

3. If a Miprom controller is used,
 - DO3, DO4, DO7, DO10, DO17, and optional DSD, SS terminals on TB1 connect to the same terminals on Miprom controller.
 - power terminals L1A and L2A are also connected to like terminals on Miprom controller.
4. If controller is other than a Miprom,
 - follow signal requirements outlined in Input & Output Terminals chart.

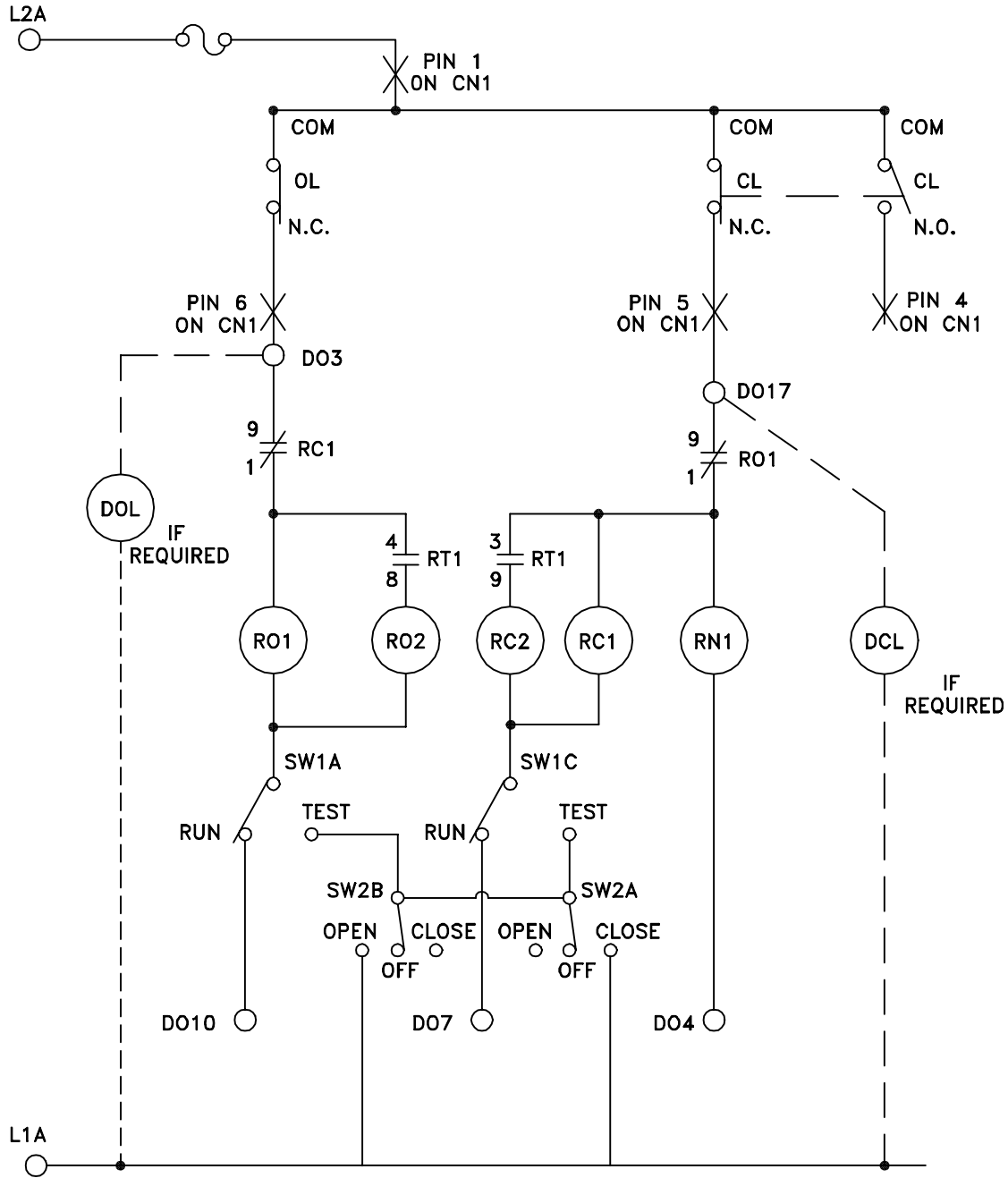

———— = FACTORY WIRING OR PRINTED CIRCUIT TRACES.
 - - - - = FIELD WIRING

A606-012(3/98)

**DOL and DCL are not required if Miprom control is used.
 They MAY be required if any other type of control is used.**



INSTALL NEW COVER

1. Drill two 21/64 inch [8.3 mm] diameter holes (8) in each end of the base assembly. (Two holes in each end of base assembly for a total of four holes.)
 - Centers of holes are located 1 inch [25.4 mm] down from top of end plate and .53 inch [13.5 mm] from side of end plate.
 - Center to center of holes is 6-3/4 inches [171.5 mm]
2. With the threaded end to the inside, install four 5/16-18 x 1-1/4 inch hex head cap screws (9) through the 21/64 inch [8.3 mm] diameter holes.
3. Secure screws with four 5/16 inch flat washers (10), four 5/16 inch lock washers (11), and 5/16 inch hex nuts (12).
4. Position new cover on 5/16-18 x 1-1/4 inch hex head cap screws (9) and secure cover with four 5/16 inch flat washers (10), four 5/16 inch lock washers (11), and 5/16 inch wing nuts (13).

A606-004 (7/97)

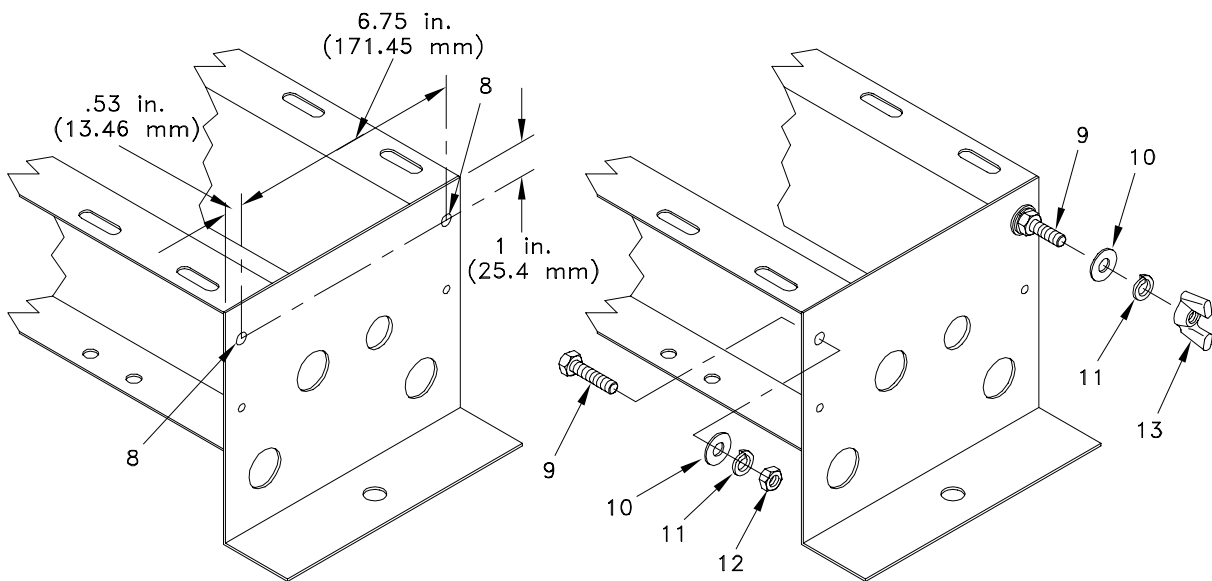

A606-009(7/97)

Adjusting door operator control Board 104®

Adjust door operator control Board 104® as follows.

- Measure current (optional)
- Set potentiometers
- Adjust door speeds
- Adjust door closing force
- Adjust nudge speed
- Set microswitch cams

Board Board 104® could be damaged if adjustment instructions are not followed carefully. If you cannot complete any of procedures as described, stop and request assistance.

A604-017 (2/97)

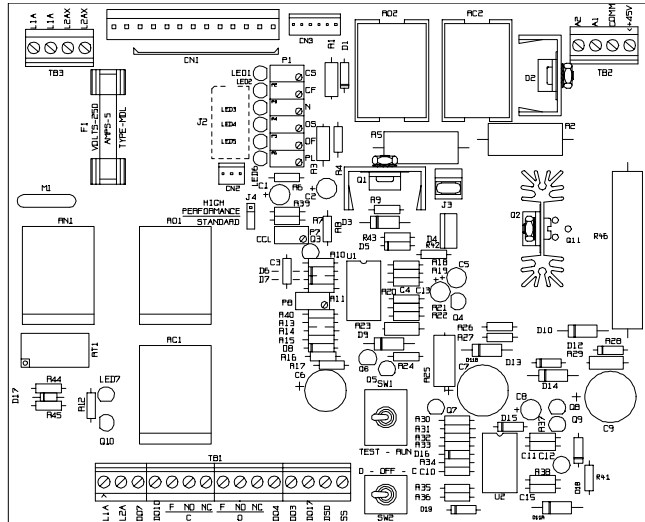

C202-H17(2/97)

Board 104®

Toggle switches

To adjust and service door control, use two toggle switches on door operator control Board 104® — TEST-RUN switch and O-OFF-C switch.

- **TEST-RUN.** TEST-RUN switch is normally in RUN position. When TEST-RUN switch is in TEST position, it disconnects normal open and close input signals from door control, and switches the O-OFF-C toggle switch into the circuit.
- **O-OFF-C.** O-OFF-C switch is normally in OFF (center) position. OFF position does not indicate input power has been removed. It only indicates no signal to open or close when TEST-RUN switch is in TEST position.

A604-S15 (2/97)

Toggle switches

To adjust and service door control, use two toggle switches on door operator control Board 1Ø4® — TEST-RUN switch and O-OFF-C switch.

- **TEST-RUN.** TEST-RUN switch is normally in RUN position. When TEST-RUN switch is in TEST position, it disconnects normal open and close input signals from door control, and switches the O-OFF-C toggle switch into the circuit.
- **O-OFF-C.** O-OFF-C switch is normally in OFF (center) position. OFF position does not indicate input power has been removed. It only indicates no signal to open or close when TEST-RUN switch is in TEST position.

A604-S15 (2/97)

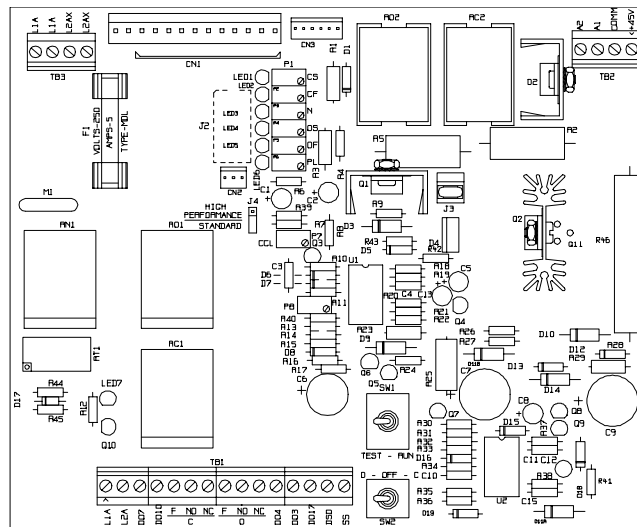

C202-H17(2/97)

Board 1Ø4®

MEASURE CURRENT (OPTIONAL)

CAUTION: Do not install an ammeter in power supply line.

Current measurements are not required to adjust door operator control Board 1Ø4®. If necessary, measure current as follows.

1. Connect a voltmeter to resistor R2 (.1 Ohm 5 watt resistor) located between heat sinks Q2 and D2.

Viewing from TB1 side of control board, right side of resistor R2 is (-) and left side of resistor R2 is (+).

2. Set voltmeter to a low range — 1 volt or 2.5 volt.
3. Read measurement with following in mind.
 - 1 volt on meter indicates 10 amps of current.
 - .5 volt on meter indicates 5 amps of current.

A604-018 (2/97)

SET POTENTIOMETERS

Make sure all potentiometers are set to ZERO, except P8. *Do not set potentiometer P8.* It is factory-set and sealed.

These multi-turn potentiometers require 25 turns to traverse their complete range.

A604-019 (3/97)



ADJUST DOOR SPEEDS

1. Disconnect and tag-out power.
2. Remove door operator cover and close doors.
3. Set switches and potentiometer in following positions.
 - All speed control potentiometers - fully counter-clockwise.
 - C.C.L. potentiometer - Fully clockwise.
 - TEST-RUN switch - TEST position.
 - O-OFF-C switch - OFF (center) position.
 - Two position jumper J4 - just to right, and slightly above, R01 relay. (*Standard* position if one pair of wires is present at TB3. *High Performance* if two pairs of wires are present at TB3.)
4. Apply power. Toggle O-OFF-C switch to “O” position. LED6 next to “PL” potentiometer illuminates, indicating doors are in PL zone.
5. Turn “PL” potentiometer clockwise until doors begin to open. When “PL” microswitch drops, LED next to “PL” potentiometer goes out, and LED next to “OF” potentiometer illuminates.
6. Turn “OF” potentiometer clockwise, just enough to move doors through “OF” speed zone. When “OSDL” microswitch drops, LED next to “OF” potentiometer goes out, and LED next to “OS” potentiometer illuminates.
7. Turn “OS” potentiometer, just enough to move door through “OS” speed zone. When “OL” cam activates “OL” microswitch, LED next to “OS” potentiometer goes out. Doors should be fully open.
8. Toggle O-OFF-C switch to C position. LED next to “CF” potentiometer comes on.
9. Turn “CF” potentiometer clockwise until doors begin to move. When “CSDL” microswitch is dropped by its cam, LED next to “CF” potentiometer goes out and LED next to “CS” potentiometer illuminates.
10. Turn “CS” potentiometer clockwise until “CL” microswitch is actuated by its CAM. LED next to “CS” potentiometer goes out. Doors should open and close at slow speed.
 - If doors do not fully open or close within 20 to 30 seconds, internal timer removes motor power and LED 7 is lit.
 - If board senses over 5 amps, power shuts down and LED 7 is lit.
11. Using speed zone potentiometer and CAM settings, adjust door speeds for desired performance. Green LED's indicate which speed control potentiometer is controlling door speed.
 - **Increase door speed** — turn potentiometer *clockwise*
 - **Decrease door speed** — turn potentiometer *counterclockwise*

Do not set potentiometer P8. It is factory-set and sealed.

A604-020 (4/97)

TIP: If doors do not operate smoothly, particularly on slower moving doors, it may help to remove jumper J3. This eliminates dynamic braking, and allows a smoother transition between speeds.

A604-S16 (2/97)

Door Operator Conversion

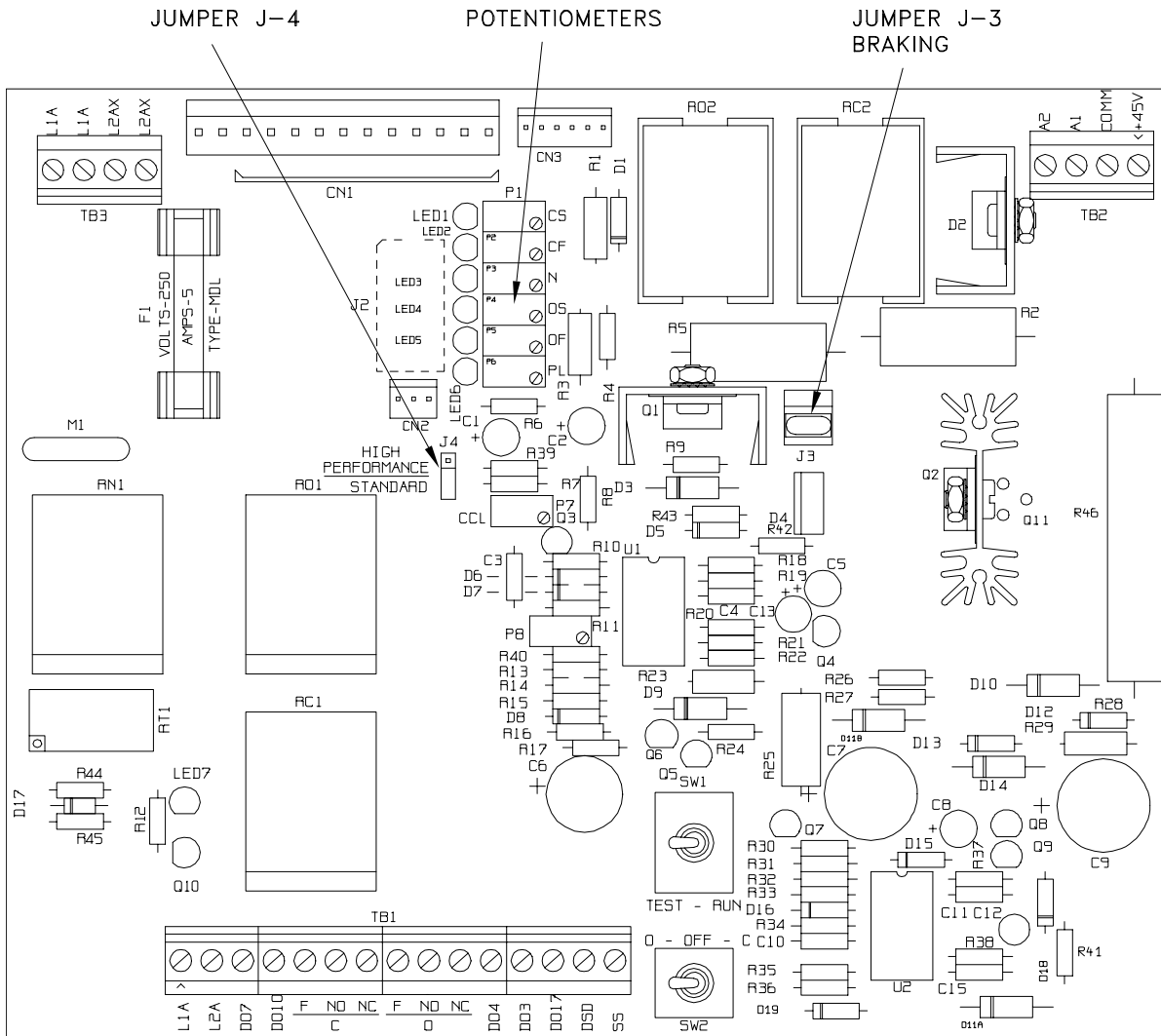

A603-121(2/97)



ADJUST DOOR CLOSING FORCE

1. Toggle TEST-RUN switch to TEST position.
2. Stop doors at mid-point in closing direction by toggling O-OFF-C switch to OFF position.
3. Turn CCL (close current limit) potentiometer fully counter-clockwise until doors stall.
4. Turn CCL potentiometer clockwise until desired door close operation is achieved. Door closing force should be less than 30 pound maximum allowed by Code.
5. To check door pressure, physically stall door at midpoint in closing direction.
6. Place rubber end of a pressure gauge (1) on edge of power-driven car door (3). Read pounds of force (2) on gauge and record results.
7. Open and close doors with O-OFF-C switch several times.
8. Physically stall doors again in closing direction and re-check door closing force with pressure gauge.

If door closing force CANNOT be kept under 30 pounds, contact Moline Accessories Company.

A604-021 (2/97)

ADJUST NUDGE SPEED

1. Simulate a nudge signal by placing a jumper on terminal strip TB-1 between L1A and DO4.
2. Set the TEST-RUN switch to TEST position.
3. Set O-OFF-C switch to C position. Doors should close at nudge speed.
4. Turn the N potentiometer clockwise to desired nudging speed.
5. Remove jumper between L1A and DO4 before returning the TEST-RUN switch to RUN.

F615-010 (2/97)

When all adjustments are complete, place O-OFF-C switch in OFF position, and TEST-RUN switch in RUN position. Replace door operator cover.

A604-S17 (2/97)

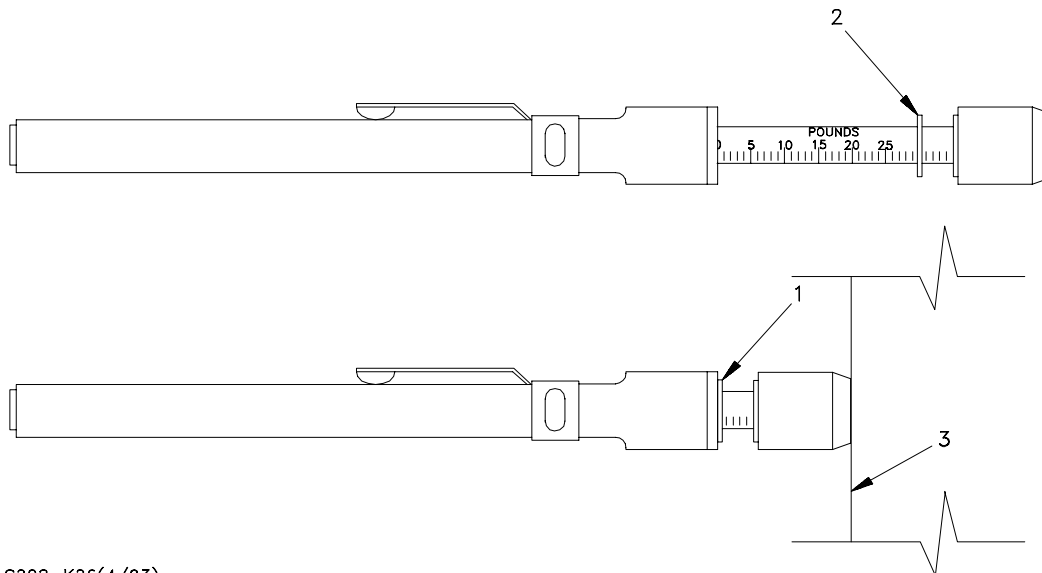

C202-K26(4/93)

SET MICROSWITCH CAMS

PM/SSC door operator microswitch cams determine where changes in door speed occur. Factory settings are approximate. Set microswitch cams, if necessary, per individual job requirements.

- CL** CAM actuates CL microswitch when doors are in their desired fully closed position.
- PL** Initial opening CAM drops microswitch when car door clutch has just engaged both hoistway door rollers, but should not drop microswitch if door interlock hangs up.
- OSDL** CAM drops OSDL microswitch when doors are approximately half open.
- CSDL** CAM drops CSDL microswitch when doors are approximately 4 inches [10.2 mm] from their fully closed position.
- OL** CAM actuates OL microswitch when doors are in fully open position.
- DSD** (optional) CAM actuates DSD microswitch when doors are approximately 4 to 6 inches [10.2 to 15.2 mm] from fully closed position. CAM can also be set for other customer requirements.

F615-009 (4/98)

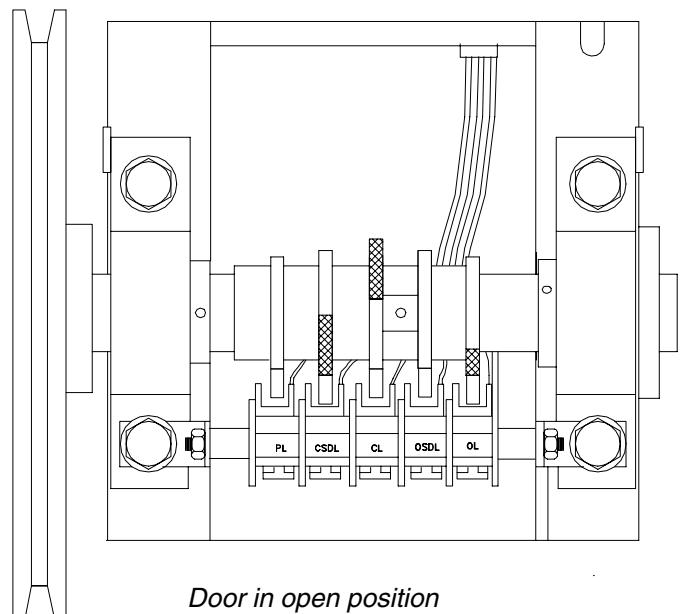
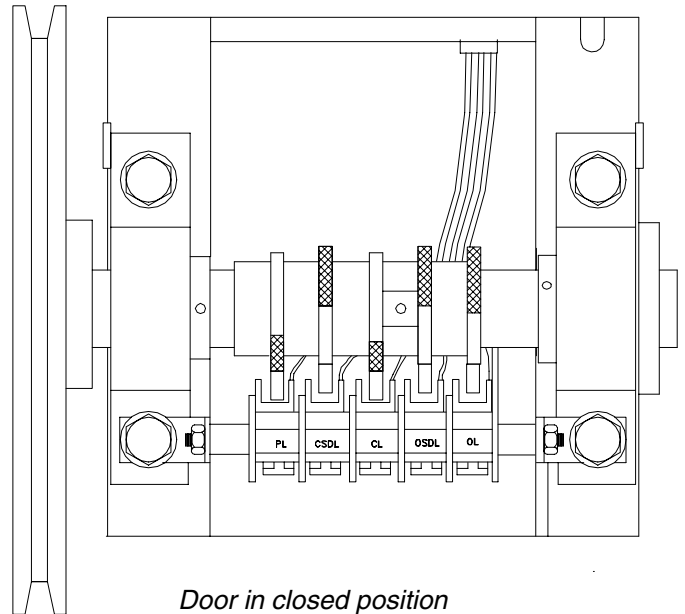

A603-122(4/93)

Replacement Parts

DOOR OPERATOR CONVERSION KIT:

Type M to PM/SSC or HPM/SSC with Board 104®

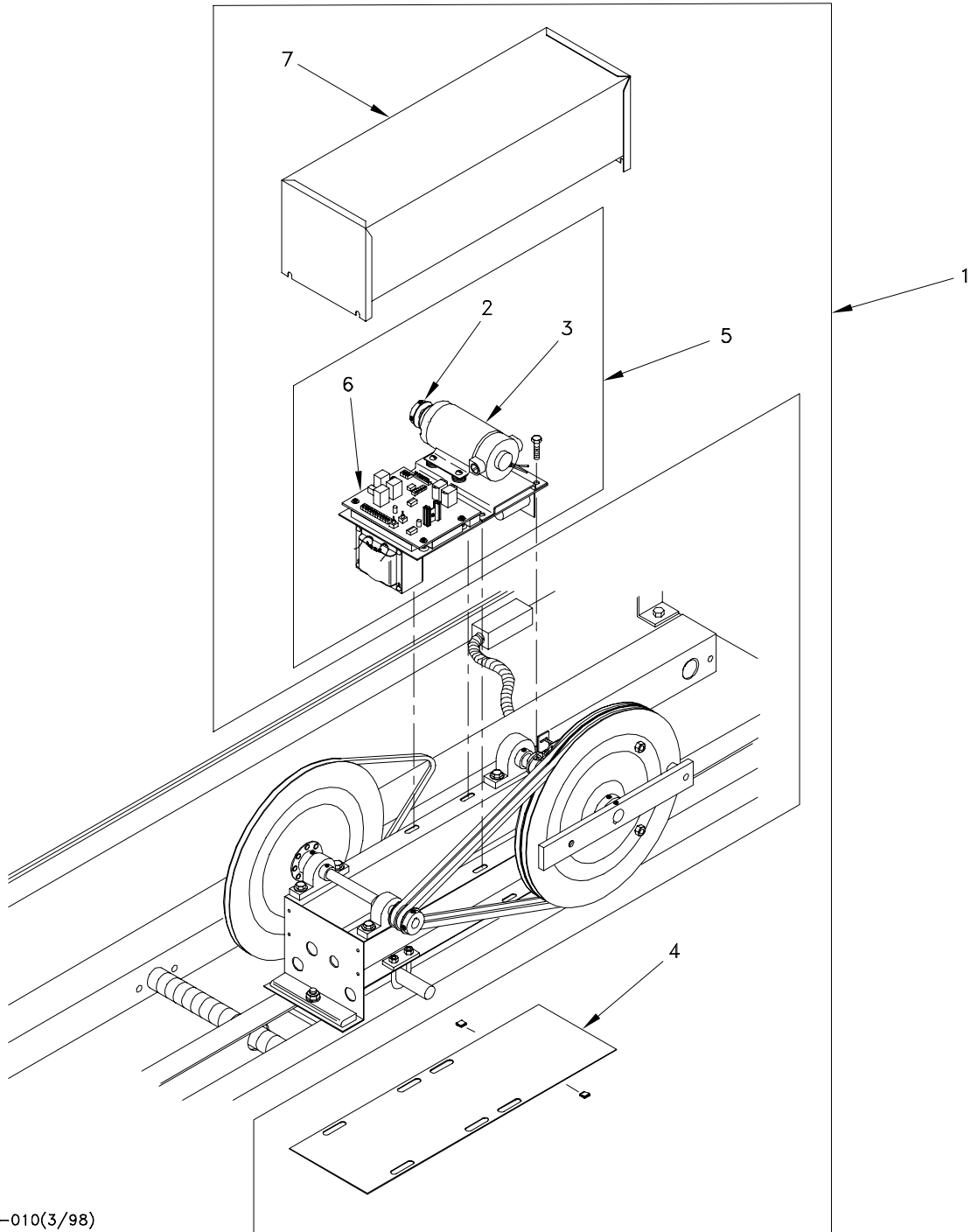

A606-010(3/98)
A606-007(3/98)

Replacement Parts

DOOR OPERATOR CONVERSION KIT: Type M to PM/SSC with Board 104®

KEY	MKOPART	PARTNAME	REMARK
1	P-22267-001	Kit, door conversion to solid state	RH, To convert type M to PMSSC; Includes motor, door control w/Board 104, and cover
	P-22267-002	Kit, door conversion to solid state	LH, To convert type M to PMSSC; Includes motor, door control w/Board 104, and cover
NS	P-22337-001	Kit, door conversion to solid state	RH, To convert type M to HPMSSC; Includes motor, door control w/Board 104, and cover
NS	P-22337-002	Kit, door conversion to solid state	LH, to convert type M to HPMSSC; Includes motor, door control w/Board 104, and cover
2	19502-031	Sheave, single	1.7 in. pitch for reduction
3	101849	Motor, permanent magnet	1/6 HP, 1140 RPM, 24 VDC
4	49744	Cover, bottom	PM/SSC
5	P-22248	Door control board 104	PM/SSC standard door control
6	P-24783	PC board, door operator	PM/SSC board 104
7	P-24186	Cover, door operator	PM/SSC
NS	46208	Transformer	32V 250VA, located on bottom of P-22248 door control
NS	46217-020	Rectifier, bridge	25A 200V, located on bottom of P-22248 door control
NS	46218	Capacitor, electrolytic	Used with Kit P-22267-***, 4500 uF, 50 WV, located on bottom of P-22248 door control
NS	49732	Capacitor, electrolytic	Used with Kit P-22337-***, 41000 uF, 50 WV for high performance power supply, located on bottom of P-22248 door control
NS	90527-022	Cable	13 connector, 18 AWG, MLX/FRK

**The following kits are also available to convert
WM door operators to WMHPMSSC door operators.**

NS	P-22268-001	Kit, door conversion to solid state	RH, to convert type WM to WMHPMSSC; Includes motor, door control w/Board 104, and cover
NS	P-22268-002	Kit, door conversion to solid state	LH, to convert type WM to WMHPMSSC; Includes motor, door control w/Board 104, and cover

NS = Not shown





MOLINE ACCESSORIES COMPANY
107 18th Street; Moline, IL 61265
Phone: 309-762-6888
FAX: 309-762-7475